

U-R-B-A-N

Trust. Right from the start!

AKS 5550

Multi head welding machine



Our know-how - your advantage

AKS 5550 with knife weld seam restriction 2.0 mm to 0.2 mm on table and clamping plate.

- A variable triple-head and four-head welding machine for angle, transom/cross welding.
- Pneumatic head adjustment for the different transom widths.
- Individual adjustment of all welding parameters such as welding temperature, heat-up time, fusing pressure, joining pressure, joining time and clamping pressure.
- Heating elements are mounted on top.
- Standard usable length: 4.0 m.
- The scope of delivery includes back fence.
- Without outer contour limitations.
- Machine cannot be extended.





- **Weld seam limitation...**
- from 0.2 mm to 2.0 mm.

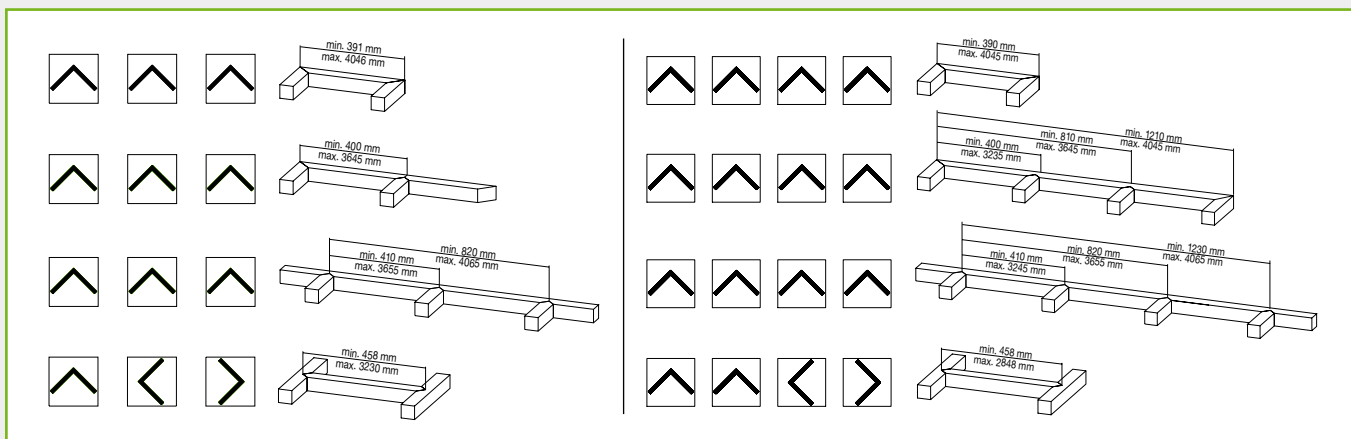

- **Flexibility...**
- the two welding heads on the right side can be turned by 90° to make H-weldings.

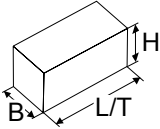

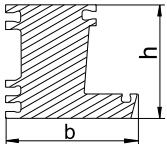
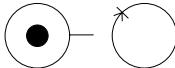
	3 head approx. 1600 kg 4 head approx. 2100 kg		L/T = 4800 mm B = 1680 mm H = 1840 mm
	230 / 400 V 50 / 60 Hz L1-L2-L3-N-PE 4/6/8 kW at 2/3/4 head		
	at 7 bar approx. 20 liters per head		

Technical data apply to basic machine without options.

Urban GmbH & Co. Maschinenbau KG • Dornierstraße 5 • DE-87700 Memmingen
Tel.: +49 (0)8331 858-0 • Fax: +49 (0)8331 858-58 • e-mail: urban@u-r-b-a-n.com
<http://www.u-r-b-a-n.com>